

Technical data

CODE:

501323

PRODUCT:

LED MODULE DXS-3

NOTE:

TECHNICAL DATA

IMAGE:**LAST UPDATE:**

9/2021

LED MODULE DXS-3

CE	RoHS	3030 SMD	3 LEDs	Injection Lens	DC 12V	IP 65	5 years
-----------	-------------	-----------------	---------------	-----------------------	---------------	--------------	----------------

Model DXS-3

3 pcs 3030 SMD LEDs, 120 x 23 x 11,5 mm, white shell, equipped with optical devices, PVC injected series, 12 V DC, constant current, LED module

Features:

- 3030 SMD LED with low attenuation and long lifetime
- Standard cascading qty up to 20 pcs
- Beam angle 17*28°
- Can be cut between every unit
- CE, RoHS compliant

Applications

Suitable for 5 - 10 cm depth 0,7 - 1,2 m width light box

Warranty

5 years or 22 000 hours, whichever comes first

Model	DXS-3
LED color	White
CCT (K)	7000 K
CRI	≥ 70
SDCM	-
Beam angle	17*28°
Total luminous flux	244 lm
Useful luminous flux	215 lm
Working voltage	12 VDC
Working current	240 mA
Power	2,8 W/pcs
IP grade	IP65
Operating temperature °C	-25 ~ +60°C
Storage temperature °C	-25 ~ +70°C
Standard cascading qty	20 pcs
Single-ended max. cascading qty	20 pcs
Double-ended max. cascading qty	40 pcs
Weight (g/piece)	25 g/pcs
Weight (lb/piece)	0,011 lb/pcs

Notes:

- (1) Testing environment temperature: 25±2°C (77±3,6°F)
- (2) The actual data of each single product may differ from above typical data which are subject to change without prior notice
- (3) The above „--“ means the parameters are not required temporarily

Profile drawings

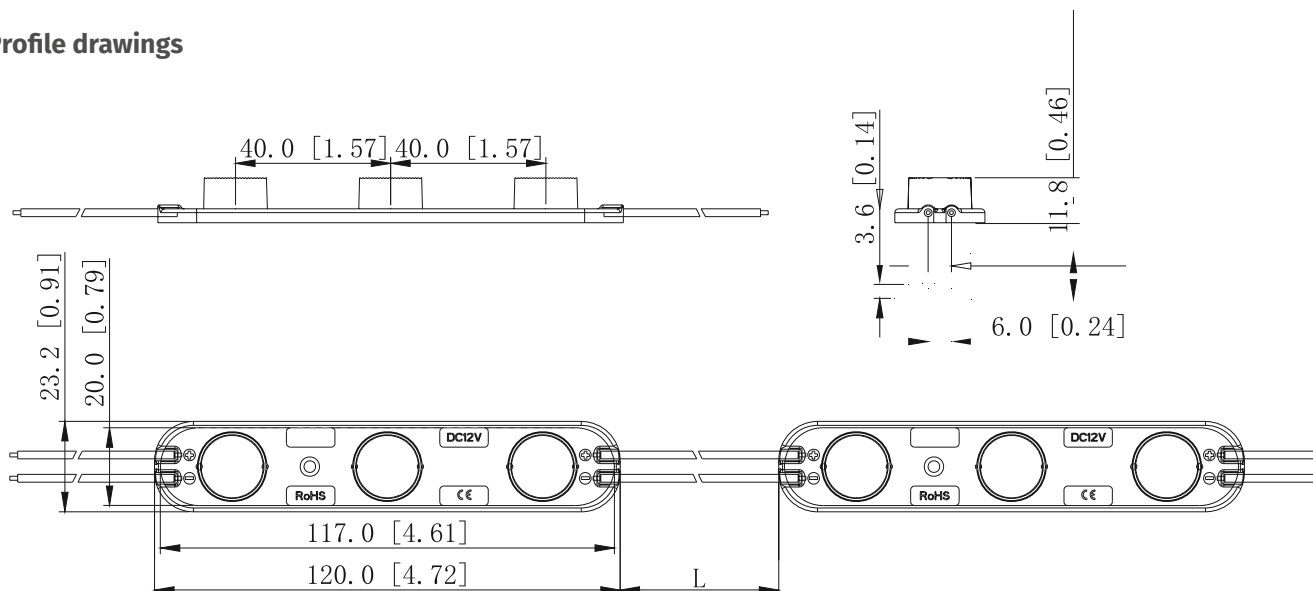

Light distribution

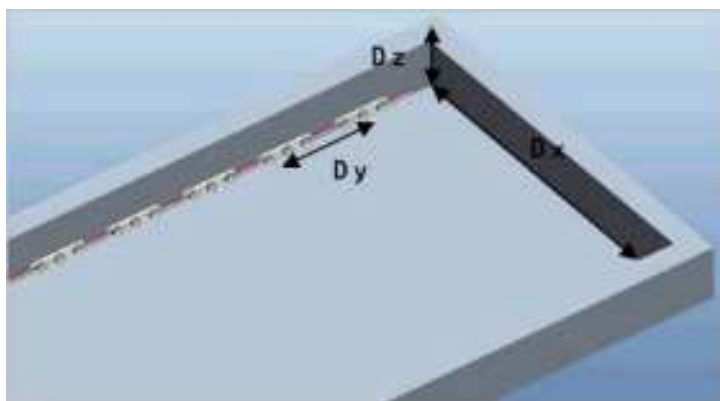
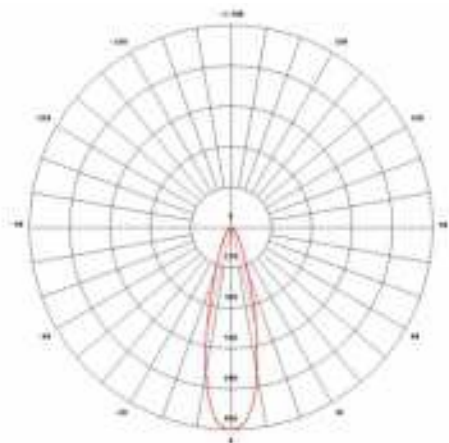

Layout data

Light box depth (mm)	Space between every unit (mm)	Installing density (pcs/m ²)	Surface average illuminance (lux)
Dz = 50	Dx = 700 Dy = 140	20	2863
Dz = 60	Dx = 700 Dy = 150	19	2743
Dz = 70	Dx = 700 Dy = 170	17	2383
Dz = 80	Dx = 700 Dy = 180	16	2272
Dz = 90	Dx = 700 Dy = 190	15	2072
Dz = 100	Dx = 700 Dy = 210	14	1914

Notes

- (1) The above data is tested from the modules with color temperature of 6 500 K
- (2) The above light box uses acrylic white board with 3 mm depth and 54,4% light transmittance
- (3) The above illuminance is the minimum value tested on the even surface
- (4) The above data is for reference only

Packaging information

P/N	Qty (pcs/ bag)	Qty (bag/ carton)	Total qty (pcs)	Total weight (kg)	Outer carton		
					Length (mm)	Width (mm)	Height (mm)
DXS-3	60	8	480	14,3	528	376	272

Packaging diagram

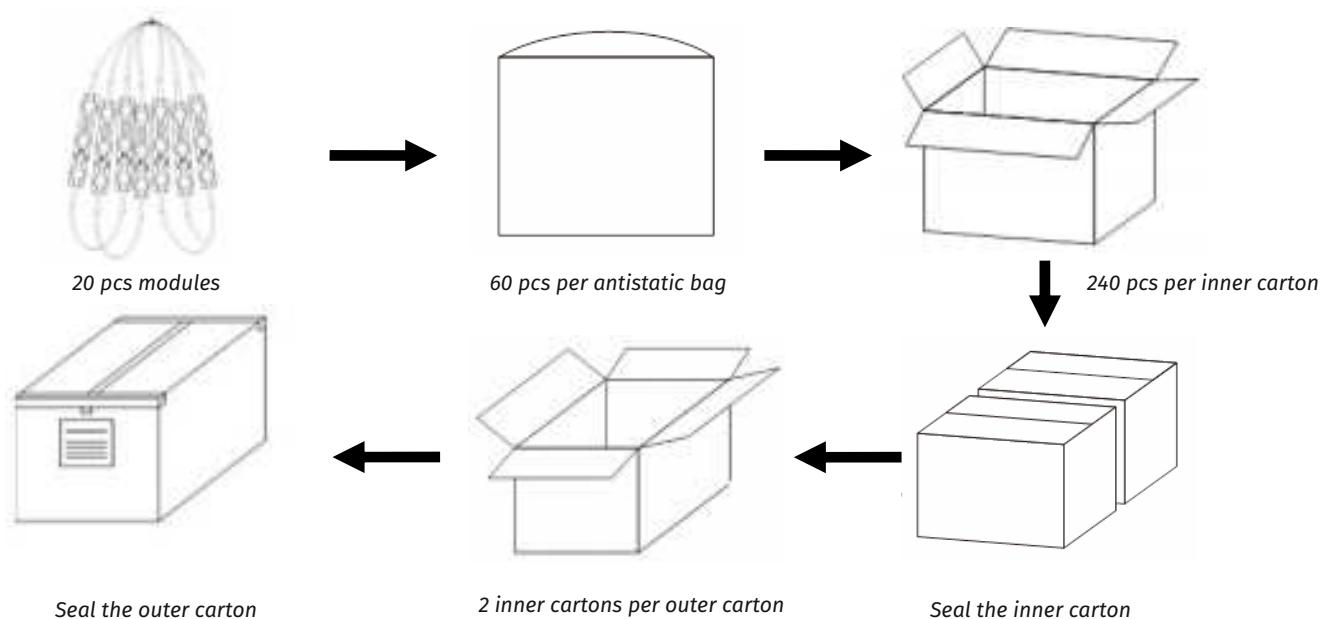

Connection instruction

Note:

Please connect the '+' and '-' of modules to those of power supply output correctly.

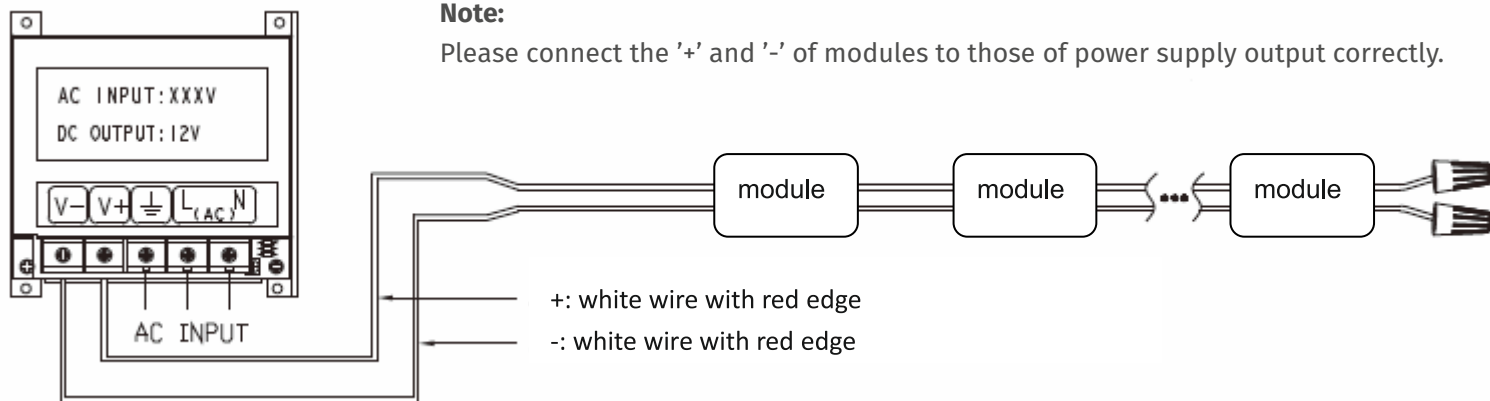

Installation steps

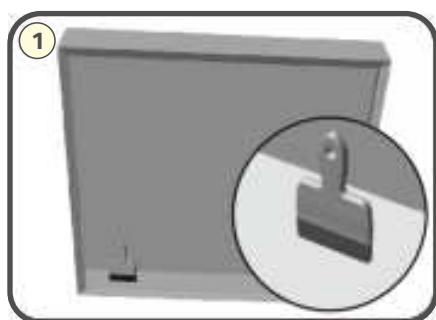

Clean the mounting surface

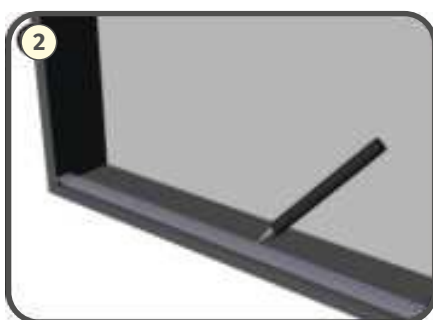

Determine the installing position for modules and the needed qty. Make sure to install it close to the bottom of the light box.

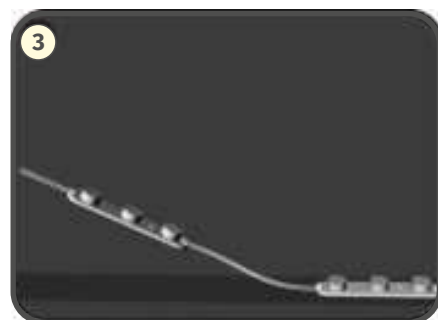

Peel off the release paper of double-sided adhesive tapes, then, stick modules on the installing surface for preliminary mounting.



Adjust the modules to the best position, press the double-sided tape tightly and then fix by screws.



Cut off the modules to the desired qty, and peel off the insulation skin of wires about 10 mm

Note: Please cut from the middle of wires between modules.

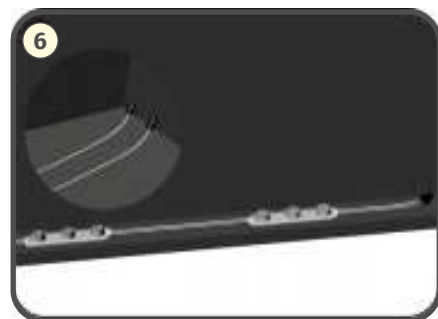

When the wires exposed in the last module, please peel off the insulation skin of wires about 10 mm each, then, screw in terminals respectively, and dispose with waterproof, insulation protection

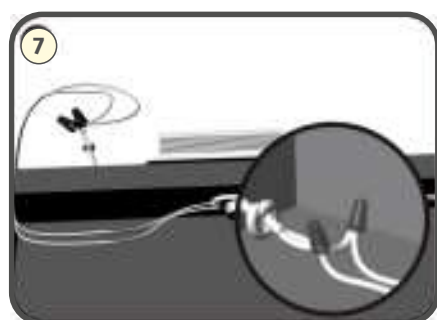

Please ensure that the '+' and '-' of the wires of modules are connected with those of power supply correctly, and dispose with waterproof, insulation, anti-circuit and anti-corrosion protection.

Troubleshooting

MALFUNCTIONS	POSSIBLE CAUSES	SOLUTIONS
All LEDs don't work	1. The power supply did not connect to power grid	Power on
	2. The electricity due to short-circuit of external power supply	Remove the malfunction caused by short-circuit, power on again
	3. The wires of module connect to power supply output reversely	Check the connecting and ensure the wires are connected correctly
Part of LEDs don't work	1. Part of power supplies do not have output	Check the power supply system
	2. Part of module wires have malfunction	
	3. Particular module connected reversely	Correct connection
Brightness of LEDs is weak or uneven	1. Overloaded power supply	Replace it with higher power supply
	2. The power loss of power circuit is huge or the power loss of each circuit existing big difference	Ensure working voltage of is within $\pm 5\%V$ of rated voltage 1. Shorten the length of wires between the first module and power supply or replaced with wires with bigger diameter; 2. Ensure the cascading qty of string is less than or equal to the allowed maximum cascading qty, and each module cascading qty is well-balanced
	3. Exceed in qty of modules in series	Lessen the cascading qty for module and ensure the qty for each electrical circuit is within the maximum cascading qty.
Brightness of LEDs is weak or uneven	1. Poor contacted in the joints	Find out and tackle malfunction immediately
	2. Failures in power supply	Replace power supply

Declaration

- If the external flexible cable of light box is damaged, please replace it by its manufacturer or its service agent or qualified person to avoid a hazard.
- The specific installation and cautions please refer to the user manual.
- The given data in this specification is based on our standard product. There may be existed slight difference compared with actual products.
- All Illustrations in this specification are for reference only.
- This product is subject to change or modify without prior notice.
- DENCOP reserves the right of final explanation for this specification.